

ENIGMA

BEETLE, DEEP, ESTANTE, ESTOLA, LA ISLA,
MAGNUM , MINI TORTUGA , PION PETRA

SANCAL 



ENIGMA

SANCAL 

Ante un panorama geopolítico rayano al apocalipsis, Sancal defiende el humor como antídoto y motor de cambio. Por ello, la nueva colección está enmarcada en una escenografía tan sobria como surrealista. Situada entre dos mundos, uno real y otro fantástico, **ENIGMA** es la puerta a una **4ª dimensión**.

Como en un cuadro de Hopper, **la ventana** es el elemento arquitectónico principal. En cada sala descubrimos unas vistas desconcertantes, acontecimientos turbadores, que superan la imaginación del voyeur que sospechaba de sus vecinos en *La ventana indiscreta*.

Imaginemos un largo pasillo central con habitaciones dispuestas de forma geométrica a ambos lados. **ENIGMA** podría ser el hotel de *El Resplandor* o la residencia de *Suspiria*. En el interior de cada estancia todo es aparentemente normal, “lo raro” está ahí fuera.

El artista **Sammy Slabbinck** es el responsable de dar el golpe de efecto. Sus bizarros collages, especialmente

comisionados para la ocasión, son el inquietante paisaje exterior. Sammy proyecta una suerte de “justicia poética” a través de las ventanas; un satírico escarmiento para todos aquellos poderosos que, tan corrupta e insolidariamente, dirigen el mundo. Su estrafalaria obra, sin duda, constituye un perfecto contrapunto a pureza formal de nuestros productos.

“ENIGMA es una incógnita ante el porvenir, es un velado grito de protesta, es la esperanza de aquellas personas que nunca perdemos humor. Pienso que mimar la puesta en escena es la mejor forma de liberar nuestra creatividad e inquietudes en cada momento, y también una buena fuente de inspiración para la comunidad de arquitectos e interioristas”. Esther Castaño-López, Directora ejecutiva de Sancal.

As we stand before a geopolitical panorama that seems almost apocalyptic, Sancal defends humour as an antidote and a driving force for change with a new collection that is set against a sober and surreal scenography. Spanning two worlds, one real and the other imaginary, the **ENIGMA** Collection opens a door to another dimension.

Just like one of Edward Hopper's paintings, **the window** forms the principal architectural element. In each room we find disconcerting vistas of turbulent events that are wilder than the wildest fantasies of the voyeur in Alfred Hitchcock's *Rear Window*.

Imagine a long central passage, with geometric rooms on both sides... **ENIGMA** could be the hotel in *the Shining* or the house in *Suspiria*. Indoors everything is apparently “normal”, but something strange is happening outside.

The artist **Sammy Slabbinck** is responsible for this dramatic effect. His bizarre collages were specially commissioned for the project. The world's

powerful, corrupt elite are depicted meeting their satirical comeuppance. Their complex nature contrasts with the soft lines of our products.

“ENIGMA is a mystery, a silent cry of protest, the hope of those of us that never lose our sense of humour. I believe that the careful mise-en-scenes of the products is the best way of freeing our creativity and concerns as well as being a good source of inspiration for architects and interior designers”. Esther Castaño-López, Managing Director of Sancal.

DEEP 06 - 17



BEEBLE 18 - 25



LA ISLA 26 - 33



MAGNUM 34 - 43



ESTANTE 44 - 49



MINI TORTUGA 50 - 57



PION PETRA 58 - 63



ESTOLA 64 - 65



DESIGNERS

RAFA GARCÍA

Rafa forma parte del corazón creativo de **Sancal**, y es autor de piezas ya clásicas para la marca como **Air** o **Eleva**. En cuanto a sus creaciones más recientes cabe destacar el aclamado **Tiptoe** y el singular **Obi**. Tras los exitosos **Rock**, **Nido** y **Folk**, nos propone un diseño altamente racional.



Rafa sits at the creative heart of **Sancal** and is the author of some of the firm's perennial designs like the **Air** or **Eleva**. His latest creations include the **Tiptoe** and the unique **Obi**. Building on the success of products like the **Rock**, **Nido** and **Folk** he believes that design should be rational.



NOTE

Note tiene sede en Estocolmo. El estudio, fundado en 2008 por un equipo multidisciplinar, realiza proyectos de interiorismo, producto y gráfica. Como diseñadores de producto, sus trabajos para **Le Chance**, **Menu**, **Zero** o **Punt** entre otras destacadas marcas han tenido amplia repercusión. **La Isla** es su segunda colaboración con **Sancal**, tras de la exitosa familia de asientos **Tonella**.

Se presentan a sí mismos del siguiente modo: *"Notar algo y hacerse notar: nuestro nombre nombra aquello que perseguimos. Nos gusta prestar atención a aquello que nos rodea y tratar de crear piezas que hagan a los demás sentir lo mismo. Buscando aquello que es único en cada proyecto y enfatizándolo, conseguimos transformar valores y sensaciones en objetos y espacios táctiles".*

Note is a Stockholm-based design studio founded in 2008 working within the fields of architecture; interior; product and graphic design as well as design strategy. Their pieces for **Le Chance**, **Menu**, **Zero** or **Punt** among other brands have become renowned worldwide. **La Isla** is their second design for **Sancal**, after the great success of the **Tonella** family.

Their philosophy is to stand out from the crowd: *"To note something, to get noticed: we are named after what we try to achieve. We like to pay attention to our surroundings, and try to create things that make others do the same. By looking at what is unique in every project and emphasizing that, we transform non-material values into tactile objects and spaces."*

MUT

Mut es un estudio de diseño multidisciplinar fundado por **Alberto Sánchez** en 2010. Su principal objetivo es experimentar para redefinir objetos cotidianos desde un punto de vista emotivo y elevar a la categoría de icono productos aparentemente sencillos. Buen ejemplo de ello son sus proyectos de cerámica hidráulica o el columpio **Náutica** de **Expormim**, aunque nuestro favorito es su cocina flotante para **Miras**. Tras la buena acogida de las mesas **Dúplex** y la creciente amistad con **Sancal**, repiten experiencia con los creativos **Beetle**.



Mut is a multidisciplinary studio founded by **Alberto Sánchez** in 2010. Its prime objective is to redefine everyday objects from an emotional point of view, to create new icons from simple products. Their philosophy can be seen in their hydraulic tiles or the swing chair that they designed for **Expormim**, although our favourite is their floating kitchen for **Miras**. After the celebrated **Dúplex** side tables and the emergent friendship with **Sancal**, they repeat the experience with the creative design of the **Beetle**.



ESTUDIUHAC

Estudiuhac está liderado por **José Manuel Ferrero**, quien tras una intensa experiencia profesional junto a **Oscar Tusquets** crea su propio estudio de diseño industrial e interiorismo. El estudio tiene una amplia experiencia en proyectos de todo tipo: restaurantes, comercios, hoteles y hasta el interior de un coche, la versión europea del **Toyota iQ**. Más allá de la automoción, en el sector del hábitat, la carrera del estudio está en plena expansión con los proyectos realizados para **Vondom**, **Punt**, **Porcelanosa** y **Gandía Blasco**. Después de la amplia y fructuosa familia **Tea** y **Casta**, vuelven a trabajar para **Sancal** con **Magnum**, un proyecto al que también auguramos mucho éxito.

Estudiuhac is led by **Jose Manuel Ferrero** who, after an intense internship with **Oscar Tusquets**, created his own industrial and interior design studio. Their experience spans a wide range of projects: restaurants, hotels, retail shops... Even a car! In fact they designed the interior of the European **Toyota iQ**. Beyond the automotive, in the habitat sector, the studio's career is booming - with projects for **Vondom**, **Punt**, **Porcelanosa** and **Gandía Blasco**. After the hit of the vast **Tea** family and **Casta** for **Sancal**, comes **Magnum**, a project with great expectations too.

ISAAC PIÑEIRO

Siguiendo la filosofía del estudio **NADADORA**, del que formó parte durante más de 10 años junto con **Cristina Alonso**, para **Isaac** prima la honestidad conceptual y la sencillez; comunicar a primera vista para desarrollar proyectos cercanos. Ha colaborado con empresas como **Lavandera**, **Sagen Ceramics**, **La Murrina**, **Nutella** o **Serralunga**. La amistad con **Sancal** viene de lejos. Fruto de esta relación celebramos productos tan aclamados y variopintos como los pufs **Elephant**, las **Sillas40** o la cúpula acústica **Tartana**. Tras, la buena acogida de los sillones y butacas **Tortuga**, este año salen del cascarón con la versión **Mini**.



Isaac preserves the essence of **NADADORA**, the design studio that he founded along with **Cristina Alonso** 10 years ago. His conceptually honest, straightforward philosophy is evident in each and every piece. He has worked with brands like **Lavandera**, **Sagen Ceramics**, **La Murrina**, **Nutella** and **Serralunga**. His friendship with **Sancal** goes back years. Some of our most acclaimed products have sprung from their pens, including the **Elephant** poufs, the **Silla40** and the **Tartana** acoustic hood. This year he launches a small variant of his tremendously comfortable **Tortuga** easy chair.



JUAN IBÁÑEZ LAX

Diseñador gráfico y de producto, Juan coordina desde 2005 la imagen corporativa de **Sancal**, participando directamente en la elaboración de escenografías, ilustraciones, catálogos y web. Los estampados de la mesa **Trazo** también son obra suya. La colección **Nudo** es su primer producto en solitario para **Sancal**.

Juan is both a product and graphic designer. He has coordinated the corporate image of **Sancal** since 2005: taking part directly in the development of scenographies, illustrations, catalogues and the website. The prints of the **Trazo** table are also part of his work. **Nudo** is the first design range that **Juan**, acting alone, has developed for **Sancal**.

IONA VAUTRIN

Tras su graduación en 2002 en la escuela de diseño de Nantes, **Ionna** trabajó en empresas de reconocido prestigio internacional como **Camper** y el estudio de **Ronan & Erwan Bouroullec**. En 2011 recibió el Grand Prize de la creación que otorga la ciudad de París y fundó su propio estudio desde el que ha trabajado para editoras como: **Industreal**, **Lexon**, **Wallpaper**, **Foscarini**, **Moustache** o **Bosa**. **Sancal** es una de sus últimas adquisiciones! En poco tiempo **Ionna** se ha convertido un valor seguro del nuevo diseño francés. Nos enamoramos de ella gracias a sus interesantes propuestas para **Foscarini**, aunque las mesitas **Pion** ocupan ahora un lugar central en nuestro corazón.



After graduating from the Nantes design school, **Ionna** worked with prestigious companies like shoemaker **Camper** and the acclaimed design studio **Ronan & Erwan Bouroullec**. She received the Grand Prize for a piece commissioned by the city of Paris in 2011 and went on to found her own studio - working with some of the sector's most important companies, such as **Industreal**, **Lexon**, **Wallpaper**, **Foscarini**, **Moustache** and **Bosa - Sancal** being the latest member of her collection. In only a few years, **Ionna** has become a rising star in French design. The company fell in love with her interesting ideas for **Foscarini**, although the **Pion** tables are now the new favourites.



DEEP
by
RAFA
GARCÍA

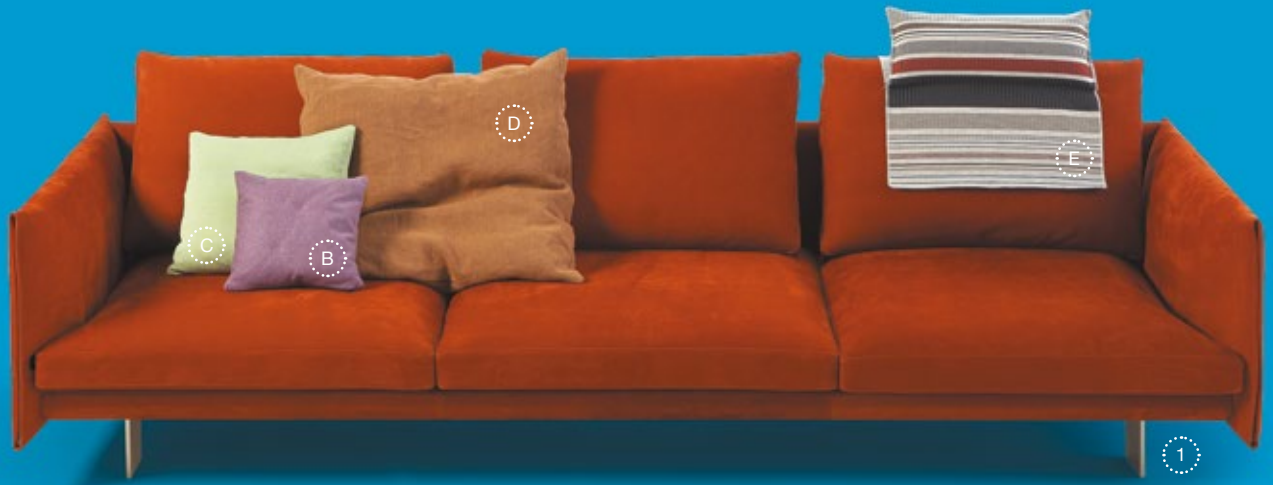

DEEP by RAFA GARCÍA



3

Sumérgete en las profundidades...

Deep es el nuevo programa modular de **Rafa García** para **Sancal**. Se trata de un diseño racional y clásico. La premisa ha sido partir de la esencia, para instaurar la máxima comodidad con el mínimo artificio. Con este diseño, **Rafa** refuerza la contemporaneidad de nuestro catálogo y demuestra que la sencillez no está reñida con el lujo.

Exteriormente la estructura de **Deep** es como una caja, el respaldo se une a los brazos remarcando ángulos y líneas rectas. En el interior en cambio la superficie es curva para potenciar el confort. El perfil del asiento tiene un diseño biselado para hacerlo casi desaparecer. Las bandas de las almohadas insisten en el racionalismo más clásico, y la separación entre las almohadas de respaldo deja espacio para vislumbrar la ya mencionada suavidad interior de la estructura. **Deep** también se caracteriza por una gran modularidad capaz de adaptarse a todos los espacios.

Los cojines auxiliares ayudan a personalizar nuestro sofá, y lo adaptan a las necesidades de ergonomía y estética de cada usuario. Gracias a la profundidad del asiento, podremos añadir una amplia combinación de almohadones y así, combinar los cojines acolchados para los brazos, con las almohadas lumbares y los cojines-estola (con textiles de **Paul Smith**) para el cabezal; hasta conseguir un **Deep** único, hecho a nuestra medida.

Los materiales y acabados disponibles son otro aspecto fundamental de su singularidad. Con **Deep** inauguramos dos nuevas colecciones textiles. El suave tacto del nubuck embauca los sentidos, mientras que la textura y movimiento del lino aporta un look mucho más desenfadado. Además, **Deep** se puede tapizar en toda la gama de tejidos **Sancal**.

Vistas de frente, las patas no son más que un sutil y delgado perfil, pero desde el lateral, cobran importancia y muestran su marcado carácter. Son de aluminio anodizado matizado y están disponibles en color carbón y oro.

Dive down to the depths ...

Deep is a new modular seating system by **Rafa García** for **Sancal**. A rational design studied to provide uncompromised comfort with the smallest footprint possible. With this design, **Rafa** reinforces the contemporary side of Sancal's catalogue and demonstrates that simplicity need not be the opposite of luxury.

The box-like exterior with its strict angles and straight lines gives way to a bulbous interior. The seat structure is bevelled to such a degree that it seems to disappear while still providing support and strength. The cushion boxing is a nod to classical rationalism with a separation that enables the padded structure to be seen. **Deep** is one of the firm's most adaptable products. A varied array of modular elements means that it can fit into a wide range of interiors.

The cushion accessories can also be used to personalise the sofa, adapting to the ergonomic and aesthetic necessities of each user. Ample scatter cushions can be

added to vary the deepness of the seat. Quilted arm cushions can be combined with lumbar supports and stole-like headrest cushions (with fabrics by **Paul Smith**) to create an infinite array of unique **Deeps**.

Materials and finishes are fundamental to a sofa's character. With **Deep** Sancal is launching two new materials, soft nubuck - ideal for the seat cushions - and less rigid, textured fabric for the back cushions. Moreover, **Deep** can be upholstered in any of the fabrics from the marque's full range.

From a front elevation, the feet are subtle and fine, but from the side they reveal their importance. Made from anodized aluminium, they are available in a gold or carbon colour.

DEEP by RAFA GARCÍA



i

4

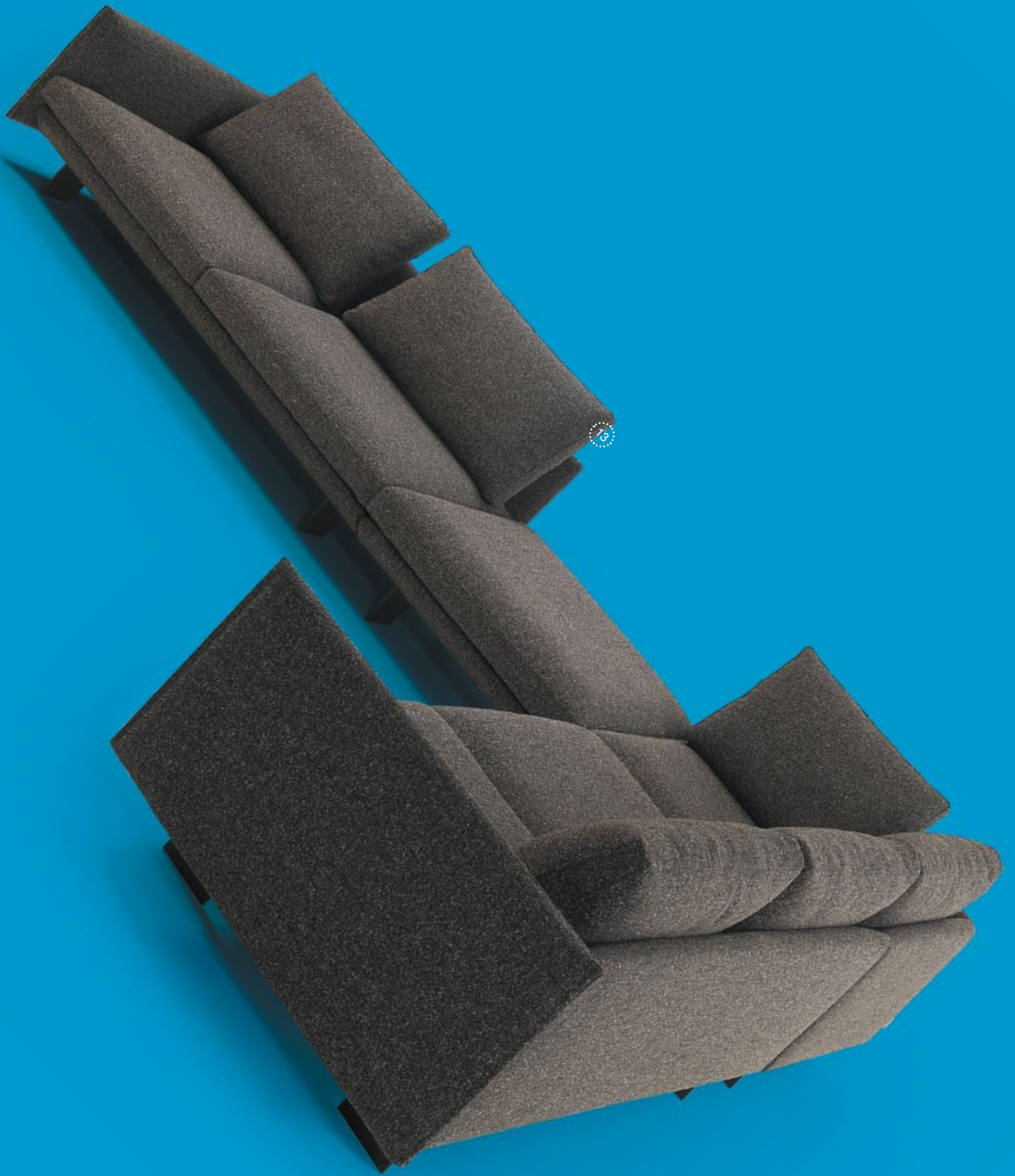



DEEP by RAFA GARCÍA



5

J

6

K

L



DEEP by RAFA GARCÍA

7

8

A

L

3

9





F

G

4



N

8



12

DEEP by RAFA GARCÍA



13

8

14

P

O



DEEP by RAFA GARCÍA

E

L

E

16

17

15



BEETLE by MUT

Acoustic panels



20

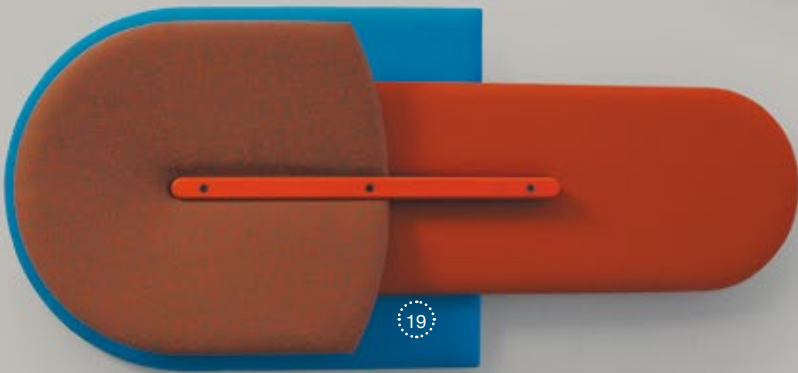

19



22

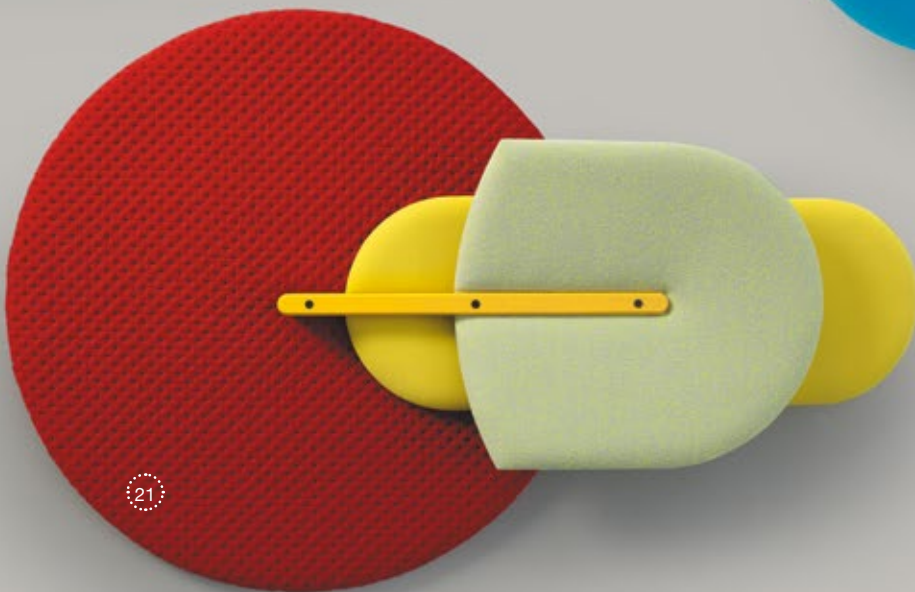

21

BEEBLE by MUT

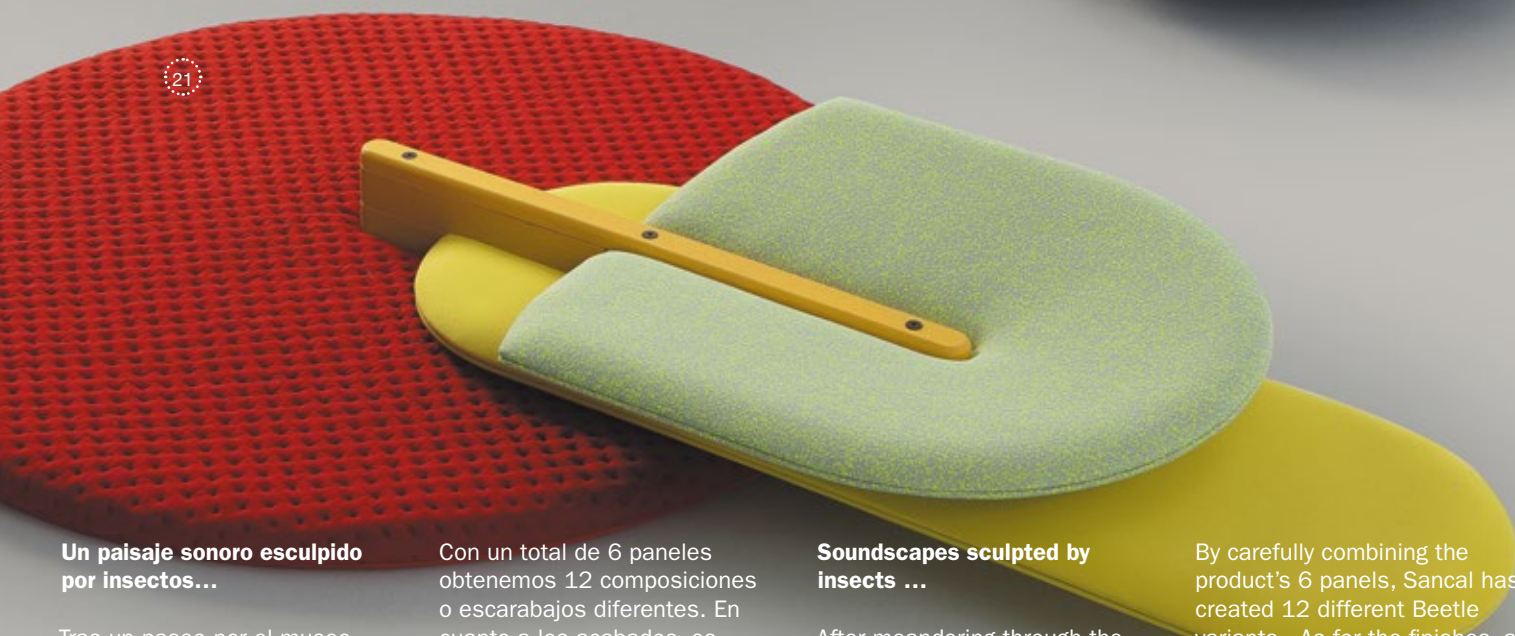
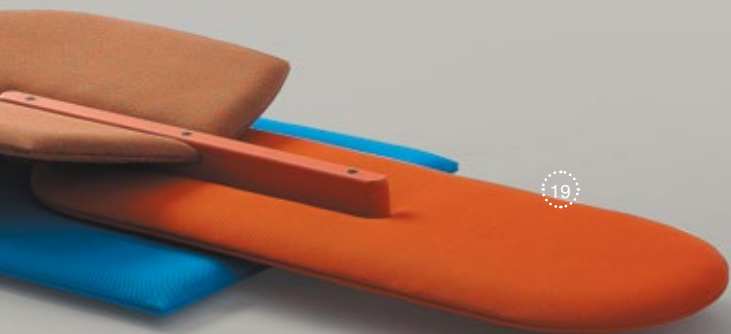

Un paisaje sonoro esculpido por insectos...

Tras un paseo por el museo de ciencias naturales, **Mut** se inspira en las salas de entomología y sus espeluznantes expositores de insectos, para crear los bichos más bellos e inofensivos jamás vistos.

El nuevo proyecto del consolidado estudio valenciano para **Sancal** parte de la necesidad de resolver el incómodo problema del ruido ambiente y hacerlo sin que lo parezca; superando el difícil equilibrio entre funcionalidad y decoración.

Los paneles fonoabsorbentes **Beetle** son esculturas textiles que sobredimensionan el arquetipo de un escarabajo.

Con un total de 6 paneles obtenemos 12 composiciones o escarabajos diferentes. En cuanto a los acabados, es posible realizar tantas combinaciones de color como te permitan los textiles. El soporte es de madera de roble y se puede tintar en cualquiera de los colores de nuestra carta.

Soundscapes sculpted by insects ...

After meandering through the Natural Science Museum, **Mut** Studio became inspired by the exhibition rooms dedicated to entomology and their terrifying showcases of insects. Their own bug, however, would be beautiful and harmless.

Their new project for **Sancal** starts with the need to resolve the uncomfortable problem of background noise, overcoming the difficult balance between sound dissipation and decoration.

The sound-absorbing panels are textile sculptures that oversize the perfect specimen of a **beetle**.

By carefully combining the product's 6 panels, Sancal has created 12 different Beetle variants. As for the finishes, a variety of textile combinations are available. The stand is made of oak wood and can be tinted in any of the colours in our chart.

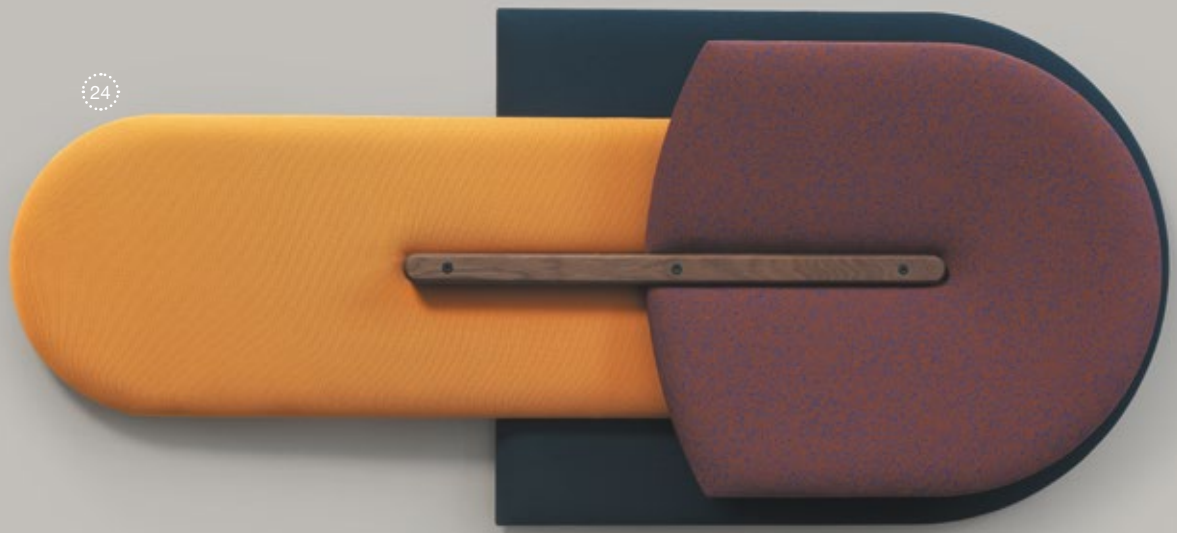

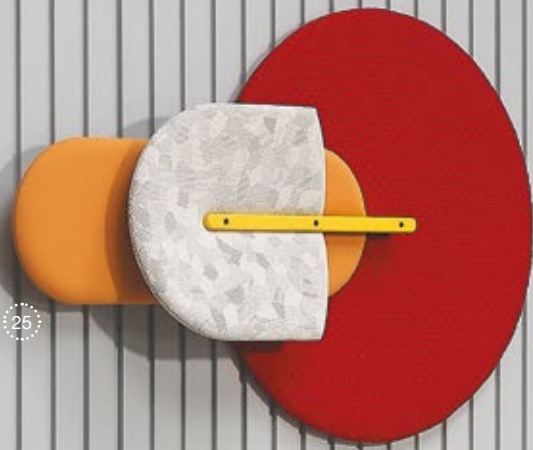

25



27



24

23



26



BEEBLE by MUT



31



24



32



33



18

34

BEEBLE by MUT



35

LA ISLA by NOTE

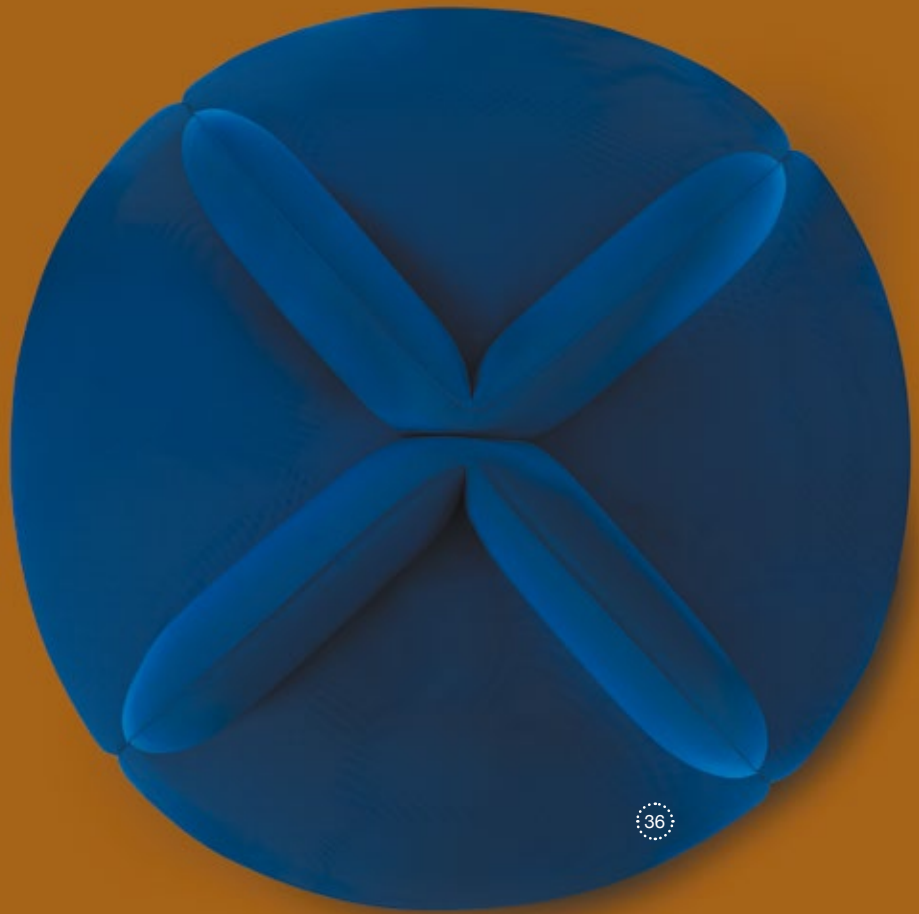

35



Un acogedor refugio para navegantes...

El nuevo proyecto de **Note Design Studio** para **Sancal** es un asiento para colectividades que responde a la proliferación de lo que **Marc Augué** denominara “no-lugares”.

Cada vez con más frecuencia nos vemos expuestos a zonas de tránsito; no-lugares generalmente inhóspitos y poco afectivos. **Sancal** ha confiado en el saber hacer del estudio sueco, con la intención de mejorar la experiencia de quienes viajan, ya sea por trabajo o placer.

¡Objetivo cumplido! **Note** ha creado un espacio de paso que permite usos simultáneos sin interferencias. Un lugar para compartir con desconocidos, pero respetuoso con nuestra

privacidad; aislado pero no excluyente.

La Isla es un banco con identidad, de amplias proporciones, generoso y amable. Perfecto para tomar un respiro en la recepción de un hotel o en la zona de espera de un aeropuerto. Su oronda silueta y curvas sinuosas crean una sentada tierna y sedosa.

La familia consta de 2 medidas y una extensa gama de tejidos. El zócalo está disponible en todos los colores de nuestra carta de lacas.

An enticing destination in a sea of nothingness...

As we travel more, we continually find ourselves in transit areas – vast seas of inhospitable and unwelcoming space that **Marc Augué** has dubbed “non-places”.

Sancal turned to **Note**, a Swedish design studio to provide some relief for weary travellers. They came up with **La Isla** as a solution. Its seductive curves and soft upholstery call out to all those navigating a lobby, desperately seeking refuge.

Once installed on **La Isla** they will not be disappointed. The upholstery is just as comfortable as it looks with generous proportions and soft materials. A place to share with strangers while respecting

their privacy; isolated but not excluded.

La Isla comes in two different sizes and a selection of fabrics from **Sancal**'s collection. The plinth can be lacquered in any of the colours as per the chart in the price list.

36

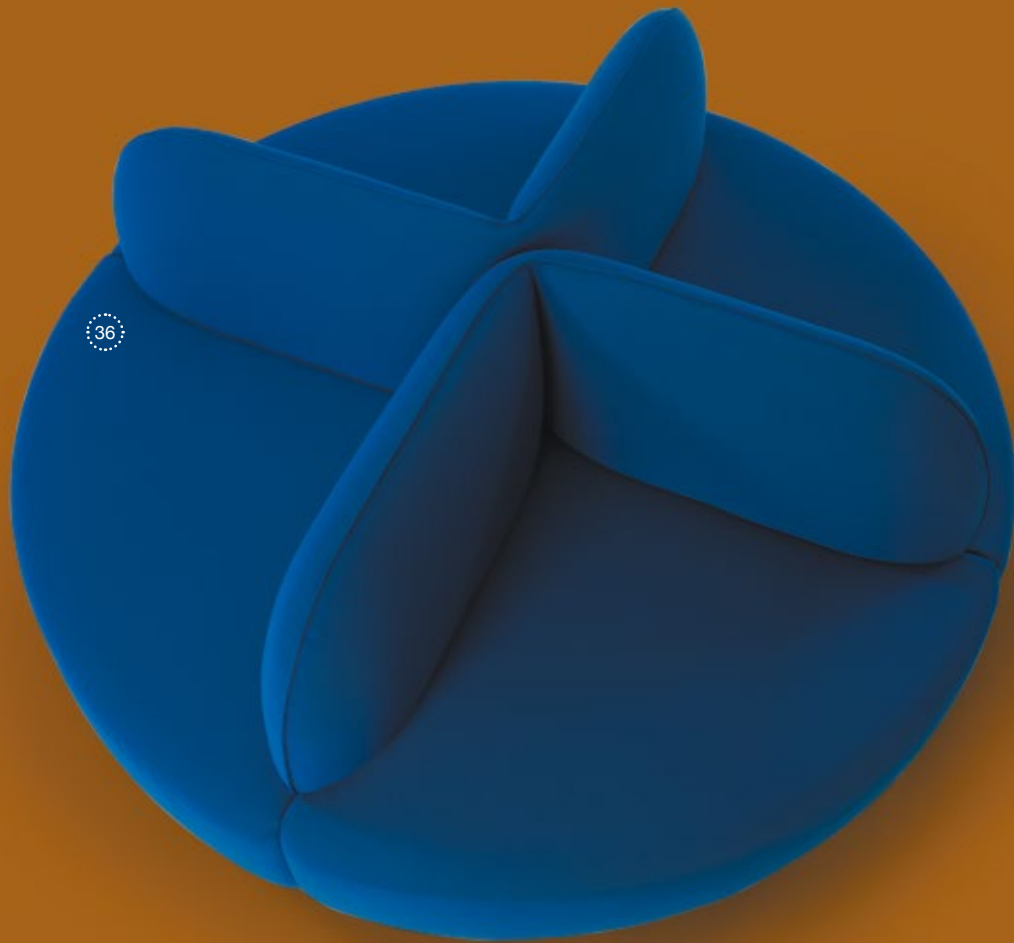

LA ISLA by NOTE



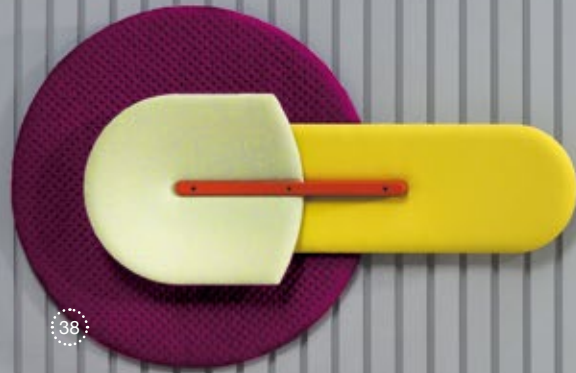



40

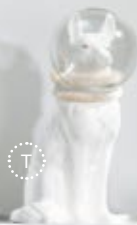

T



41

U



S

37

LA ISLA by NOTE



42

V

8

36



LA ISLA by NOTE

36

43

44

45



MAGNUM

17

by

ESTUDI HAC



45



46



47

Inspirada en la exquisitez de Savile Row

EstudiHac hace proyectos de alta costura con alto riesgo y su fundador, **José Manuel Ferrero**, es auténtico gentleman.

Para **Ferrero** la elegancia es ante todo una actitud y los británicos saben mucho de esto; por ello la inspiración de **Magnum** nace de las copas de coñac que la alta sociedad londinense tomaba mientras discutía de política en sus exclusivos clubs.

Se trata de una familia de asientos especialmente diseñada para el sector de la hostelería, sin embargo, gracias a sus formas sinuosas, su elevado confort y reducidas dimensiones, tanto las sillas como los taburetes y las butacas, pueden amueblar los hogares más singulares.

Esta polivalencia se materializa en una amplia oferta de tejidos y acabados para las bases: con patas metálicas o de madera, con base tapizada, con zócalo o pie central.

Designed in the Savile Row tradition

EstudiHac's José Manuel Ferrero might be Spanish, but his approach to design is akin to the bespoke tailoring of Mayfair.

His new range of soft seating for **Sancal**, the **Magnum**, pays homage to this very British elegance. The gentleman designer has drawn inspiration from the glasses of cognac members of exclusive London clubs cradle in their hands as they debate politics.

Comprising stools, lounge chairs and dining chairs, the range has been designed to withstand both demanding public spaces and domestic use. Even the smallest spaces can now enjoy luxurious comfort with these compact, fully upholstered pieces.

The products can all be customised by selecting from a wide array of options. The bases can be: gold coloured plinths, lacquered metal central feet, upholstery bases or four legs.

48



49





CH

T

43

52

14

44



MAGNUM by ESTUDIHC



49



55



57

56



N

W

50

33

58

49

MAGNUM by ESTUDIHC



59

60

60



31



61



66



W

U

X

62



58

MAGNUM by ESTUDIOHAC



ESTANTE

by JUAN

IBÁÑEZ

LAX

Acoustic furniture

¡Tela, metal y madera!

Estante es un mueble modular con propiedades acústicas. Los estantes de metal son el esqueleto, la pieza central entorno a la cual gira todo. A ellos se añaden las patas y pilastras de roble que los sustentan. Pero sin duda, la máxima distinción viene dada por las piezas textiles que los engalanan.

Los módulos y puertas tapizadas revisten los estantes e incorporan un diseño fono-absorbente, trascendiendo así la función decorativa. Las puertas favorecen el contraste de materiales. Las puertas de metal han sido perforadas para generar una atractiva textura y no obstaculizar la fono-absorción.

Estante es tan versátil que amplía el concepto de almacenaje auxiliar. Dependiendo de cómo sea configurado hace las veces de aparador, recibidor, librería, mueble de tv y hasta de separador de ambientes.

Fabric, metal and wood!

Estante is a modular piece of furniture with acoustic properties.

The metal shelves form the platforms upon which everything else is built. Oak pillars and feet are attached before the distinctive upholstered elements are simply slid into place.

These panels, along with the upholstered doors are sound absorbing, transcending their obvious decorative function.

Contrasting the upholstered doors or metal doors can also be added. The perforated steel forms an attractive texture minimising interference with the acoustic properties of the piece.

The furniture's highly configurable design enables it to be used as sideboard, bookcase, television stand or a divider, to name but a few potential use cases.





67



11

X



68

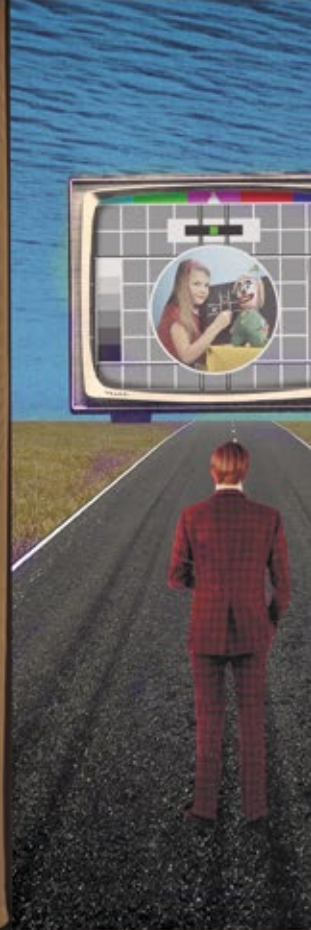



69

70

W

ESTANTE by JUAN IBÁÑEZ LAX

71

3



W

72

10

53



73

74

76

N

75

8

ESTANTE by JUAN IBÁÑEZ LAX



**MINI
TORTUGA
by ISAAC
PIÑEIRO**



MINI TORTUGA by ISAAC PINEIRO



La teoría de la evolución comienza en las Galápagos...

La nueva versión **Mini** de los sillones y butacas **Tortuga** promete ser una evolución en toda regla.

De una tortuga admiramos su longevidad y su paso lento. Por ello, cuando **Isaac**, del estudio **Nadadora**, aceptó el reto de proyectar un sillón que se convirtiera en una merecida recompensa, en un objeto con el que soñamos de camino a casa, no dudó en inspirarse en este singular animal.

La propuesta parte de un caparazón que nos abraza sin miedo al qué dirán, donde dar rienda suelta al mundo de las letras o al de los sueños... Su simpleza formal conecta y continúa con la filosofía tranquila del estudio, si bien, la profusión de los textiles seleccionados lo traslada a una dimensión mucho más exuberante.

Tras el éxito cosechado por sus progenitores, **Isaac** propone unas mini butaquitas súper confortables que harán las delicias de cualquier salón. Pero también son idóneas para como cafeterías y habitaciones de hotel, donde la falta de espacio es condicionante.

Gracias a las nuevas incorporaciones, la familia **Tortuga** se adapta mejor a todo tipo de ecosistemas. Los pufs y mesitas complementan la oferta.

The theory of evolution started with the Galapagos tortoise.

Our own **Tortuga**, Spanish for tortoise, has undergone a mutation of its own with two new mini versions of the lounge chairs.

We admire the slow, stately pace of a tortoise and envy its long life. When **Isaac**, from **Nadadora** design studio, took on the challenge to come up with a timeless design, a chair that we could dream of as we plod back home, inspiration from this enduring animal reared its head.

The idea stems from a shell that we can withdraw into, immersing ourselves in a good novel or drifting off to sleep... Its simplicity reflects the tranquility of **Nadadora's** ethos, although the choice of textiles can add contrasting exuberance.

After the success of its forbearers, **Isaac** proposes some comfortable mini lounge chairs that will be a delight in any space, also, they are suitable for projects like cafés and hotel rooms where space is compromised.

And so, with the new additions, the **Tortuga** family adapts even better to its environment with a range of full-sized and mini lounge chairs. Poufs and side tables complete the collection.



MINI TORTUGA by ISAAC PINEIRO





84

85

8

8

86

MINI TORTUGA - by ISAAC PINEIRO



V

84

15

77



MINI TORTUGA by ISAAC PINEIRO



PION PETRA by IONNA VAUTRIN

¡Nuevo jaque mate!

Tras el éxito de la familia de mesas **Pion**, ampliamos la oferta de acabados. Al igual que con sus predecesoras, la inspiración viene de las figuras del ajedrez.

Denominamos **Pion Petra** a esta recién estrenada versión porque Ionna ha recurrido a la **piedra natural** para seleccionar la nueva gama de acabados. Los sobres de cuarcita se fusionan con el color cuarzo de las bases, mientras que los sobres de mármol emperador gold contrastan con el color tabaco.

Las medidas disponibles en la versión **petra** son: D50x40, D50x60 y 240x100x74. Además, en esta versión, el lacado de la base se aplica tanto al cono como al pilar central.

Los nuevos colores lacados, cuarzo y tabaco, también se pueden combinar con los pilares y sobres de madera de la versión original. En las banquetas, el asiento es piel de vacuno del mismo color de la base.

¡Checkmate again!

After the success of the **Pion family** of tables, we have expanded the number of finishes that are available. As with its predecessors, the inspiration comes from chess pieces.

We refer to the new version as **Pion Petra**, after the ancient city carved from a rock face, as Ionna has been influenced by natural stone. The base and pillar is lacquered MDF for both the side and dining tables. Quartzite tabletops are combined with quartz coloured bases and the emperador gold marble has been contrasted against a tobacco lacquer.

The sizes available in the Pion Petra range are: D50x40, D50x60 and 240x100x74.

The new quartz and tobacco lacquer can also be applied to the standard range. In the case of the stool, the leather seat comes in the same colour as the base.

33



PION PETRA by IONNA VAUTRIN

87



15



11





49



V

Z

U

X

57



31

62

57

49

PION PETRA by IONNA VAUTRIN



83

50

15



2

89

PION PETRA by IONNA VAUTRIN

33

88

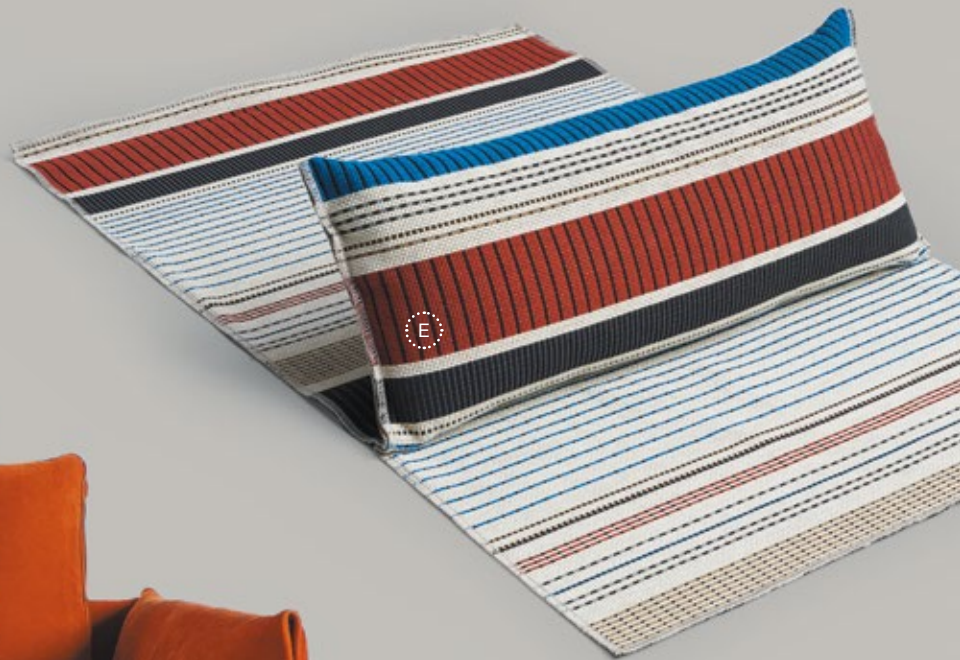

Amor a primera vista.

Estola es un astuto y sencillo **cojín** que amplifica el confort de cualquier sofá y aporta un toque de color.

Su diseño está a medio camino entre un cojín y una mantita. **Estola** recibe su nombre por las solapas que caen a ambos lados del respaldo, las cuales facilitan que el cojín quede perfectamente ubicado. Estas solapas tienen una importante presencia, por ello la elección del tejido es fundamental.

Quando nuestra directora de arte tuvo entre sus manos la colección **Point** de **Paul Smith** para **Maharam** x **Kvadrat**, supo que **Estola** era el producto perfecto para lucir sus singulares estampados sin recargar el ambiente.

Estola también está disponible sin ningún tipo de estampado en el tejido **Facet**.

Love at first sight.

Estola is an ingenious **cushion** that enhances the comfort of any sofa, adding a touch of colour.

Its fabric flaps sit either side of the sofas back cushion holding a padded headrest in place. This, combined with the special stitching and peculiar design, meant that a distinctive fabric with just the right weight had to be found.

When our art director was presented with the fabric **Point** by **Paul Smith** for **Maharam** x **Kvadrat** she knew she had found the ideal material. The fabric's elaborate pattern might be overwhelming for an entire sofa, but is perfect for this large cushion. Its structure enables it to perch on top of a cushion with ease. For those yearning a calmer option she also selected the plain fabric **Facet**.

ESTOLA

by

SANCAL

STUDIO

Headrest

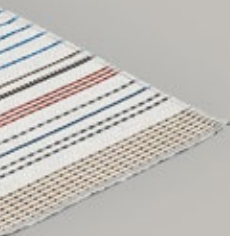

F



A



E



AA



AB



AC

Technical index

ID	UNI.	MOD.	REF.	DESCRIPCIÓN / DESCRIPTION	ACABADO FINISHES	TELAS / FABRICS		SERIES	MUESTRARIO SAMPLE
						ALMOHADA CUSHION	BASE		
0	1	DEEP	312.142.L.D	CHAISE 101X151 BR DCHO CHAISE 101 X151 RIGHT ARM	CARBON	6119	6	115	
0	1	DEEP	312.12.V.I	MOD 196 BR IZDO MOD 196 LEFT ARM	CARBON	6119	6	115	
1	1	DEEP	312.11.Z3	SOFA 267 SOFA 267	ORO GOLD	NABUK 19	12	NABUCK	
2	1	DEEP	312.11.U	SOFA 182 SOFA 182	ORO GOLD	6157	6	117	
3	1	DEEP	312.11.K	SILLON 97 ARMCHAIR 97	CARBON	GALAXY 548	7	KVADRAT	
4	1	DEEP	312.11.W	SOFA 202 SOFA 202	ORO GOLD	6153	6	117	
5	1	DEEP	312.142.L.I	CHAISE 101X151 BR IZDO CHAISE 101 X151 LEFT ARM	CARBON	6176	6	119	
5	1	DEEP	312.12.V.D	MOD 196 BR DCHO MOD 196 RIGHT ARM	CARBON	6176	6	119	
6	1	NUDO	280.71.DDEY	NUDO MESA D38X45 NUDO TABLE D38X45	056 ROJO RED	-	-	-	
7	1	DUPLEX	309.71.LDE	MESA 103X38X41 TABLE 103X38X41	003 NOGAL WALNUT / 113 MANGO	-	-	-	
7	1	DUPLEX	309.32.ED	BANDEJA 48X38 TRAY 48X38	043 MANGO	-	-	-	
8	1	TORTUGA	305.71	MESA D41X45 TABLE D41X45	002 NATURAL	-	-	-	
9	1	TORTUGA	305.56	BASE BUTACA MINI MINI LOUNGE CHAIR BASE	043 MANGO	PULSAR 679	11	KVADRAT RAF SIMONS	
9	1	TORTUGA	305.56.R	RESPALDO BUTACA MINI MINI LOUNGE CHAIR BACK	-	PULSAR 679	11	KVADRAT RAF SIMONS	
10	1	DEEP	312.11.S	SOFA 162 SOFA 162	CARBON	2803	3	118	
11	1	PION PETRA	284.71.FE.A6.Q	MESITA D50X40 CUARZO OCCASIONAL TABLE D50X40 QUARTZITE	126 CUARZO QUARTZITE	-	-	-	
12	1	DEEP	312.152.KK	PUF 95X95 POUF 95 X 95	ORO GOLD	6153	6	117	
13	1	DEEP	312.12.V.I	MOD 196 BR IZDO MOD 196 LEFT ARM	CARBON	6119	6	115	
13	1	DEEP	312.161	ANGULO RECTO 101X101 ANGLE 101 X101	CARBON	6119	6	115	
13	1	DEEP	312.157.KK	PUF 95X101 CENTRAL CENTRAL POUF 95X101	CARBON	6119	6	115	
13	1	DEEP	312.12.V.D	MOD 196 BR DCHO MOD 196 RIGHT ARM	CARBON	6119	6	115	
14	1	VESPER	308.71.MKD	MESA 105X93X33 TAPA MADERA TABLE 105X93X33 WOODEN TOP	052 KLEIN / GRIS TOPO TOPE-GREY	-	-	-	
15	1	PION PETRA	284.71.FE.A6.G	MESITA D50X40 EMPERADOR GOLD OCCASIONAL TABLE D50X40 EMPEROR GOLD	127 TABACO TOBACCO	-	-	-	
16	1	DUPLEX	309.71.LDE	MESA 103X38X41 TABLE 103X38X41	002 NATURAL / 001 NEGRO BLACK	-	-	-	
16	1	DUPLEX	309.32.ED	BANDEJA 48X38 TRAY 48X38	002 NATURAL	-	-	-	
17	1	MAGNUM	311.55	BUTACA PIE CENTRAL LACADO LOUNGE CHAIR LACQ. CENTRAL LEG	123 ULTRAMAR	8053	7	111	
18	1	BEETLE	315.F.410C	CONFIG. 410C	-	-	-	-	
			315.3A.4P	PANEL 4 PLANO PANEL 4 FLAT	-	STITCH CAMEL	10	FEBRIK	
			315.3A.1C	PANEL 1 CONCAVO PANEL 1 CONCAVE	-	SPRINKLES FINCH	9	FEBRIK	
			315.3H.C	SOPORTE C SUPPORT C	002 NATURAL	-	-	-	

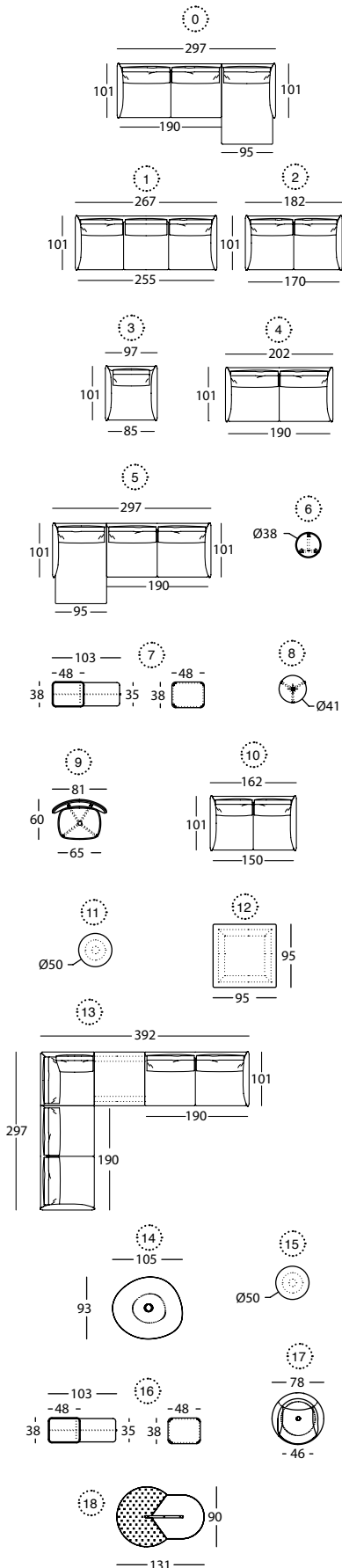

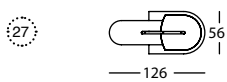
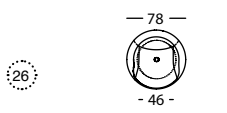
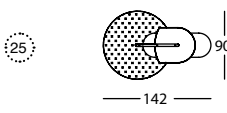
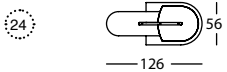
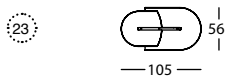
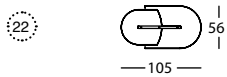
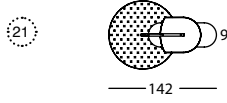
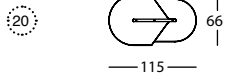
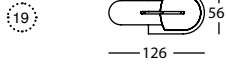

ID	UNL.	MOD.	REF.	DESCRIPCIÓN / DESCRIPTION	ACABADO FINISHES	TELAS / FABRICS		SERIES	MUESTRARIO SAMPLE
						ALMOHADA CUSHION	BASE		
19	1	BEETLE	315.F.653D	CONFIG. 653D					
			315.3A.6P	PANEL 6 PLANO PANEL 6 FLAT	-	ATLANTIC 66125	2	112 / ATLANTIC	
			315.3A.5P	PANEL 5 PLANO PANEL 5 FLAT	-	ATLANTIC 63057	2	112 / ATLANTIC	
			315.3A.3C	PANEL 3 CONCAVO PANEL 3 CONCAVE	-	GALAXY 548	7	KVADRAT	
20	1	BEETLE	315.F.210A	CONFIG. 210A	043 MANGO				
			315.3A.2C	PANEL 2 CONCAVO PANEL 2 CONCAVE	-	ATLANTIC 66041	2	112 / ATLANTIC	
			315.3A.1C	PANEL 1 CONCAVO PANEL 1 CONCAVE	-	GALAXY 608	7	KVADRAT	
21	1	BEETLE	315.F.453E	CONFIG. 453E	042 AMARILLO YELLOW				
			315.3A.4P	PANEL 4 PLANO PANEL 4 FLAT		STITCH PASSION	10	FEBRIK	
			315.3A.5P	PANEL 5 PLANO PANEL 5 FLAT		ATLANTIC 62049	2	112 / ATLANTIC	
			315.3A.3C	PANEL 3 CONCAVO PANEL 3 CONCAVE		GALAXY 408	7	KVADRAT	
22	1	BEETLE	315.F.230B	CONFIG. 230B					
			315.3A.2C	PANEL 2 CONCAVO PANEL 2 CONCAVE	-	ATLANTIC 66125	2	112 / ATLANTIC	
			315.3A.3C	PANEL 3 CONCAVO PANEL 3 CONCAVE	-	GALAXY 348	7	KVADRAT	
23	1	BEETLE	315.F.230B	CONFIG. 230B	043 MANGO				
			315.3A.2C	PANEL 2 CONCAVO PANEL 2 CONCAVE	-	FACET 1008	4	107 / FACET	
			315.3A.3C	PANEL 3 CONCAVO PANEL 3 CONCAVE	-	RAZZLE DAZZLE BASE	9	FEBRIK	
			315.3H.B	SOPORTE B SUPPORT B	056 ROJO / RED				
24	1	BEETLE	315.F.653D	CONFIG. 653D					
			315.3A.6P	PANEL 6 PLANO PANEL 6 FLAT	-	ATLANTIC 67043	2	112 / ATLANTIC	
			315.3A.5P	PANEL 5 PLANO PANEL 5 FLAT	-	ATLANTIC 63033	2	112 / ATLANTIC	
			315.3A.3C	PANEL 3 CONCAVO PANEL 3 CONCAVE	-	GALAXY 348	7	KVADRAT	
25	1	BEETLE	315.F.453E	CONFIG. 453E	003 NOGAL WALNUT				
			315.3A.4P	PANEL 4 PLANO PANEL 4 FLAT		STITCH PASSION	10	FEBRIK	
			315.3A.5P	PANEL 5 PLANO PANEL 5 FLAT		ATLANTIC 63033	2	112 / ATLANTIC	
			315.3A.3C	PANEL 3 CONCAVO PANEL 3 CONCAVE		RAZZLE DAZZLE NATURAL	9	FEBRIK	
26	1	MAGNUM	311.55	BUTACA PIE CENTRAL LACADO LOUNGE CHAIR LACQUERED CENTRAL LEG	042 AMARILLO YELLOW				
					095 GRIS SEDA SILK GREY	STEELCUT TRIO 3 113	7	KVADRAT	
27	1	BEETLE	315.F.653D	CONFIG. 653D					
			315.3A.6P	PANEL 6 PLANO PANEL 6 FLAT	-	ATLANTIC 62049	2	112 / ATLANTIC	
			315.3A.5P	PANEL 5 PLANO PANEL 5 FLAT	-	UNIFORM MELANGE ICE	8	FEBRIK	
			315.3A.3C	PANEL 3 CONCAVO PANEL 3 CONCAVE	-	GALAXY 548	7	KVADRAT	
			315.3H.D	SOPORTE D SUPPORT D	043 MANGO				

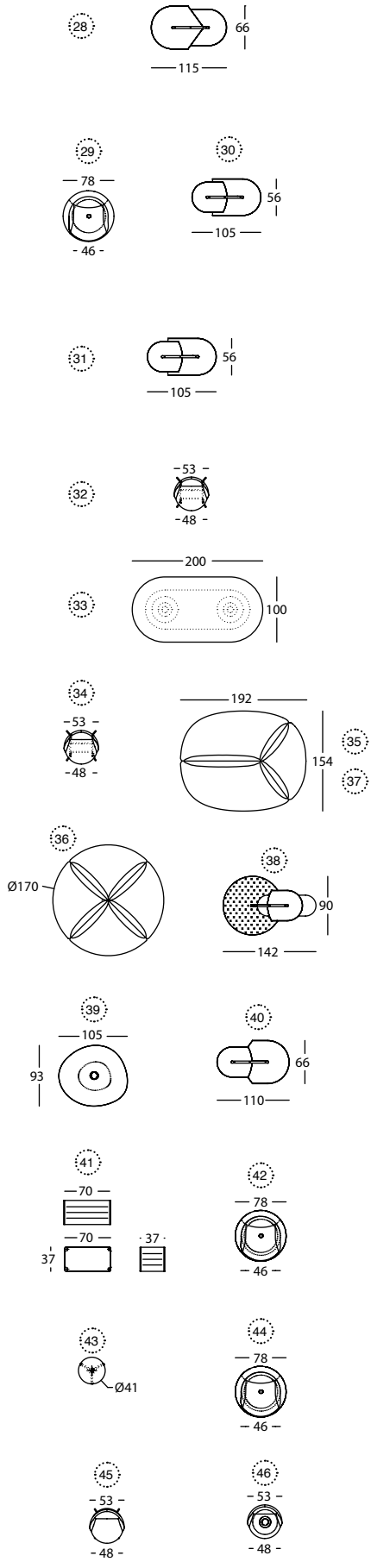

ID	UNL.	MOD.	REF.	DESCRIPCIÓN / DESCRIPTION	ACABADO FINISHES	TELAS / FABRICS		SERIES	MUESTRARIO SAMPLE
						ALMOHADA CUSHION	BASE		
28	1	BEETLE	315.F.210A	CONFIG. 210A	-	-	-	-	-
			315.3A.2C	PANEL 2 CONCAVO PANEL 2 CONCAVE	-	ATLANTIC 66125	2	112 / ATLANTIC	
			315.3A.1C	PANEL 1 CONCAVO PANEL 1 CONCAVE	-	GALAXY 608	7	KVADRAT	
29	1	MAGNUM	311.55	BUTACA PIE CENTRAL LACADO LOUNGE CHAIR LACQUERED CENTRAL LEG	042 AMARILLO YELLOW 096 CREMA CREAM	-	2787	3	110
			315.F.230B	CONFIG. 230B	-	-	-	-	-
			315.3A.2C	PANEL 2 CONCAVO PANEL 2 CONCAVE	-	RAZZLE DAZZLE GINGER	9	FEBRIK	
30	1	BEETLE	315.3A.3C	PANEL 3 CONCAVO PANEL 3 CONCAVE	-	-	GALAXY 408	7	KVADRAT
			315.3H.A	SOPORTE A SUPPORT A	043 MANGO	-	-	-	
			315.3H.B	SOPORTE B SUPPORT B	-	-	-	-	
31	1	BEETLE	315.F.230B	CONFIG. 230B	-	-	-	-	-
			315.3A.2C	PANEL 2 CONCAVO PANEL 2 CONCAVE	-	FACET 01	4	107 / FACET	
			315.3A.3C	PANEL 3 CONCAVO PANEL 3 CONCAVE	-	RAZZLE DAZZLE NATURAL	9	FEBRIK	
32	1	MAGNUM	311.41.7	SILLA PATAS METAL CHAIR WITH METAL FEET	006 ANTRACITA ANTHRACITE	-	-	-	-
			315.3A.2C	PANEL 2 CONCAVO PANEL 2 CONCAVE	-	-	-	-	
			315.3A.3C	PANEL 3 CONCAVO PANEL 3 CONCAVE	-	-	-	-	
32	1	MAGNUM	311.41.7	SILLA PATAS METAL CHAIR WITH METAL FEET	ORO GOLD	GALAXY 548	7	KVADRAT	
33	1	PION PETRA	284.74.WLH.A6.G	MESA 200X100X74 EMPERADOR GOLD TABLE 200X100X74 EMPEROR GOLD	127 TABACO TOBACCO	-	-	-	
34	1	MAGNUM	311.41.7	SILLA PATAS METAL CHAIR WITH METAL FEET	ORO GOLD	STEP 2440 63075	3	108 (1/2) / STEP	
35	1	LA ISLA	314.10.VRH	LA ISLA BANCO 192X154 LA ISLA BENCH 192X154	113 MANGO	UM CORAL	8	FEBRIK	
36	1	LA ISLA	314.10.TTH	LA ISLA BANCO D170 LA ISLA BENCH D170	123 ULTRAMAR	ATLANTIC 66126	2	112 / ATLANTIC	
37	1	LA ISLA	314.10.VRH	LA ISLA BANCO 192X154 LA ISLA BENCH 192X154	113 MANGO	GALAXY 608	7	KVADRAT	
38	1	BEETLE	315.F.453E	CONFIG. 453E	-	-	-	-	-
			315.3A.4P	PANEL 4 PLANO PANEL 4 FLAT	-	STITCH FUCHSIA	10	FEBRIK	
			315.3A.5P	PANEL 5 PLANO PANEL 5 FLAT	-	ATLANTIC 62049	2	112 / ATLANTIC	
39	1	VESPER	315.3A.3C	PANEL 3 CONCAVO PANEL 3 CONCAVE	-	-	GALAXY 408	7	KVADRAT
			315.3H.E	SOPORTE E SUPPORT E	043 MANGO	-	-	-	
			308.71.MKD.S	MESA 105X93X33 TAPA STONACRIL TABLE 105X93X33 STONACRIL TOP	BLANCO WHITE	-	-	-	
40	1	BEETLE	315.F.130B	CONFIG. 130B	-	-	-	-	-
			315.3A.1C	PANEL 1 CONCAVO PANEL 1 CONCAVE	-	GALAXY 948	7	KVADRAT	
			315.3A.3C	PANEL 3 CONCAVO PANEL 3 CONCAVE	-	RAZZLE DAZZLE NATURAL	9	FEBRIK	
41	1	ESTANTE	313.86.HDK	MODULO 70X37X96 MODULE 70X37X96	043 MANGO	-	-	-	-
			313.8A.HD	TRASERA TEXTIL FONOABSORBENTE 70X37 PHONO-ABSORBENT QUILTED BACK PANEL 70X37	-	UNIFORM MELANGE SOLAR	8	FEBRIK	
			313.8A.DD	COSTADO TEXTIL FONOABSORBENTE 37X37 PHONO-ABSORBENT QUILTED SIDE PANEL 37X37	-	UNIFORM MELANGE SOLAR	8	FEBRIK	
42	1	MAGNUM	311.55.Z	BUTACA CON ZÓCALO LOUNGE CHAIR WITH PLINTH	ORO GOLD	STEP 2440 65018	3	108 (1/2) / STEP	
43	1	TORTUGA	305.71	MESA D41X45 TABLE D41X45	045 ROSA PINK	-	-	-	-
			311.55.Z	BUTACA CON ZÓCALO LOUNGE CHAIR WITH PLINTH	ORO GOLD	GALAXY 408	7	KVADRAT	
44	1	MAGNUM	311.464	TABURETE PATAS METAL STOOL WITH METAL FEET	ORO GOLD	ATLANTIC 66125	2	112 / ATLANTIC	
46	1	MAGNUM	311.47	SILLA PIE CENTRAL LACADO CHAIR LACQUERED CENTRAL LEG	122 OPALO OPAL	ATLANTIC 64117	2	112 / ATLANTIC	

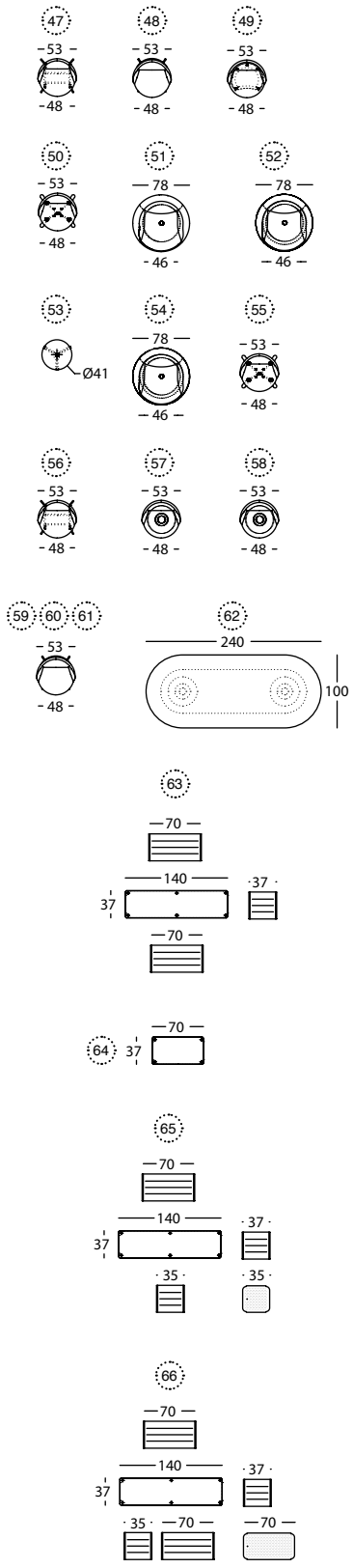

ID	UNL.	MOD.	REF.	DESCRIPCIÓN / DESCRIPTION	ACABADO FINISHES	TELAS / FABRICS		SERIES	MUESTRARIO SAMPLE
						ALMOHADA CUSHION	BASE		
47	1	MAGNUM	311.41.7	SILLA PATAS METAL CHAIR WITH METAL FEET	001 NEGRO BLACK		8072	7	116
48	1	MAGNUM	311.464	TABURETE PATAS METAL STOOL WITH METAL FEET	001 NEGRO BLACK		FACET 01	4	107 / FACET
49	1	MAGNUM	311.41	SILLA BASE TAPIZADA CHAIR WITH UPHOLSTERED BASE	-		OUTBACK 221	8	KVADRAT
50	1	MAGNUM	311.41.6	SILLA PATAS MADERA CHAIR WITH WOODEN FEET	043 MANGO		STEELCUT TRIO 3 553	7	KVADRAT
51	1	MAGNUM	311.55	BUTACA PIE CENTRAL LACADO LOUNGE CHAIR LACQUERED CENTRAL LEG	043 MANGO		6119	6	115
52	1	MAGNUM	311.55.Z	BUTACA CON ZÓCALO LOUNGE CHAIR WITH PLINTH	122 OPALO OPAL		FACET 1000	4	107 / FACET
53	1	TORTUGA	305.71	MESA D41X45 TABLE D41X45	052 KLEIN		-	-	-
54	1	MAGNUM	311.55.Z	BUTACA CON ZÓCALO LOUNGE CHAIR WITH PLINTH	ORO GOLD		CRYSTAL FIELD 773	10	KVADRAT
55	1	MAGNUM	311.41.6	SILLA PATAS MADERA CHAIR WITH WOODEN FEET	002 NATURAL		RAZZLE DAZZLE NATURAL	9	FEBRIK
56	1	MAGNUM	311.41.7	SILLA PATAS METAL CHAIR WITH METAL FEET	001 NEGRO BLACK		GALAXY 178	7	KVADRAT
57	1	MAGNUM	311.47	SILLA PIE CENTRAL LACADO CHAIR LACQ. CENTRAL LEG	124 CHAMPANGE		8062	7	111
58	1	MAGNUM	311.47	SILLA PIE CENTRAL LACADO CHAIR LACQ. CENTRAL LEG	125 BERENGENA AUBERGINE		FACET 73	4	107 / FACET
59	1	MAGNUM	311.464	TABURETE PATAS METAL STOOL WITH METAL FEET	ORO GOLD		ATLANTIC 64093	2	112 / ATLANTIC
60	2	MAGNUM	311.464	TABURETE PATAS METAL STOOL WITH METAL FEET	ORO GOLD		GALAXY 608	7	KVADRAT
61	1	MAGNUM	311.464	TABURETE PATAS METAL STOOL WITH METAL FEET	001 NEGRO BLACK		ATLANTIC 66125	2	112 / ATLANTIC
62	1	PION PETRA	284.74.ZLH.A6.Q	MESA 240X100X74 CUARZO TABLE 240X100X74 QUARTZITE	126 CUARZO QUARTZITE		-	-	-
63	1	ESTANTE	313.86.QDK	MODULO 140X37X96 MODULE 140X37X96	043 MANGO		-	-	-
63	4	ESTANTE	313.8A.HD	TRASERA TEXTIL FONOABSORVENTE 70X37 PHONO-ABSORBENT QUILTED BACK PANEL 70X37	-		UNIFORM MELANGE JEANS	8	FEBRIK
63	4	ESTANTE	313.8A.DD	COSTADO TEXTIL FONOABSORVENTE 37X37 PHONO-ABSORBENT QUILTED SIDE PANEL 37X37	-		UNIFORM MELANGE JEANS	8	FEBRIK
63	2	ESTANTE	313.8B.T.H	PUERTA TEXTIL FONOABSORVENTE 70 PHONO-ABSORBENT QUILTED DOOR 70	-		UNIFORM MELANGE JEANS	8	FEBRIK
64	1	ESTANTE	313.86.HDK	MODULO 70X37X96 MODULE 70X37X96	043 MANGO		-	-	-
65	1	ESTANTE	313.86.QDF	MODULO 140X37X59 MODULE 140X37X59	043 MANGO		-	-	-
65	2	ESTANTE	313.8A.HD	TRASERA TEXTIL FONOABSORVENTE 70X37 PHONO-ABSORBENT QUILTED BACK PANEL 70X37	-		UNIFORM MELANGE CORAL	8	FEBRIK
65	2	ESTANTE	313.8A.DD	COSTADO TEXTIL FONOABSORVENTE 37X37 PHONO-ABSORBENT QUILTED SIDE PANEL 37X37	-		UNIFORM MELANGE CORAL	8	FEBRIK
65	1	ESTANTE	313.8B.T.D	PUERTA TEXTIL FONOABSORVENTE 35 PHONO-ABSORBENT QUILTED DOOR 35	-		UNIFORM MELANGE CORAL	8	FEBRIK
65	1	ESTANTE	313.8B.M.D	PUERTA METAL 35 METAL DOOR 35	GRIS GREY		-	-	-
66	1	ESTANTE	313.86.QDP	MODULO 140X37X134 MODULE 140X37X134	052 KLEIN		-	-	-
66	6	ESTANTE	313.8A.HD	TRASERA TEXTIL FONOABSORVENTE 70X37 PHONO-ABSORBENT QUILTED BACK PANEL 70X37	-		UNIFORM MELANGE SOLAR	8	FEBRIK
66	6	ESTANTE	313.8A.DD	COSTADO TEXTIL FONOABSORVENTE 37X37 PHONO-ABSORBENT QUILTED SIDE PANEL 37X37	-		UNIFORM MELANGE SOLAR	8	FEBRIK
66	1	ESTANTE	313.8B.T.D	PUERTA TEXTIL FONOABSORVENTE 35 PHONO-ABSORBENT QUILTED DOOR 35	-		UNIFORM MELANGE SOLAR	8	FEBRIK
66	1	ESTANTE	313.8B.T.H	PUERTA TEXTIL FONOABSORVENTE 70 PHONO-ABSORBENT QUILTED DOOR 70	-		UNIFORM MELANGE SOLAR	8	FEBRIK
66	1	ESTANTE	313.8B.M.H	PUERTA METAL 70 METAL DOOR 70	GRIS GREY		-	-	-

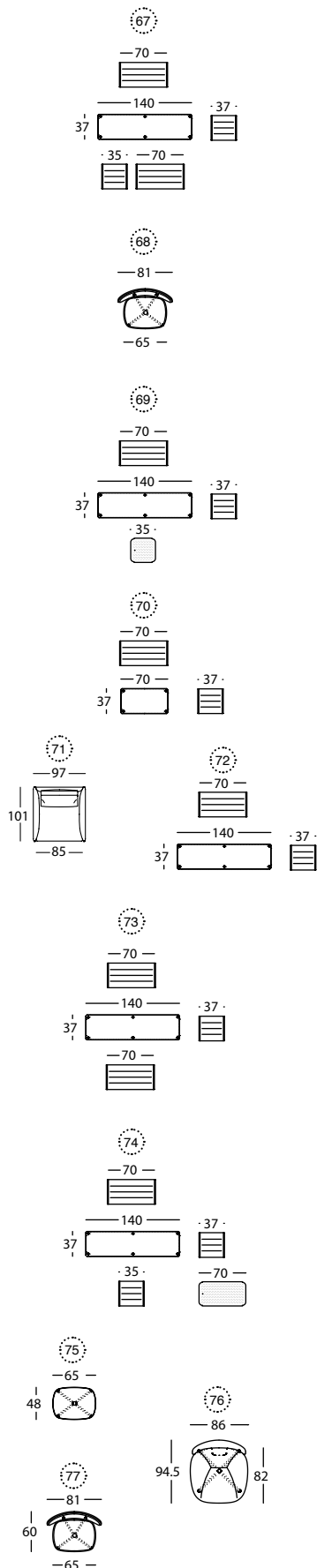

ID	UNI.	MOD.	REF.	DESCRIPCIÓN / DESCRIPTION	ACABADO FINISHES	TELAS / FABRICS		SERIES	MUESTRARIO SAMPLE
						ALMOHADA CUSHION	BASE		
67	1	ESTANTE	313.86.QDK	MODULO 140X37X96 MODULE 140X37X96	002 NATURAL	-	-	-	-
67	4	ESTANTE	313.8A.HD	TRASERA TEXTIL FONOABSORVENTE 70X37 PHONO-ABSORBENT QUILTED BACK PANEL 70X37	-	UNIFORM MELANGE JEANS	8	FEBRIK	-
67	4	ESTANTE	313.8A.DD	COSTADO TEXTIL FONOABSORVENTE 37X37 PHONO-ABSORBENT QUILTED SIDE PANEL 37X37	-	UNIFORM MELANGE JEANS	8	FEBRIK	-
67	1	ESTANTE	313.8B.T.D	PUERTA TEXTIL FONOABSORVENTE 35 PHONO-ABSORBENT QUILTED DOOR 35	-	UNIFORM MELANGE JEANS	8	FEBRIK	-
67	1	ESTANTE	313.8B.T.H	PUERTA TEXTIL FONOABSORVENTE 70 PHONO-ABSORBENT QUILTED DOOR 70	-	UNIFORM MELANGE JEANS	8	FEBRIK	-
68	1	TORTUGA	305.56	BASE BUTACA MINI MINI LOUNGE CHAIR BASE	042 AMARILLO YELLOW	BORREGUILLO / HAIRY WOOL	3	-	-
68	1	TORTUGA	305.56.R	RESPALDO BUTACA MINI MINI LOUNGE CHAIR BACK	-	BORREGUILLO / HAIRY WOOL	3	-	-
69	1	ESTANTE	313.86.QDF	MODULO 140X37X59 MODULE 140X37X59	043 MANGO	-	-	-	-
69	2	ESTANTE	313.8A.HD	TRASERA TEXTIL FONOABSORVENTE 70X37 PHONO-ABSORBENT QUILTED BACK PANEL 70X37	-	UNIFORM MELANGE JEANS	8	FEBRIK	-
69	2	ESTANTE	313.8A.DD	COSTADO TEXTIL FONOABSORVENTE 37X37 PHONO-ABSORBENT QUILTED SIDE PANEL 37X37	-	UNIFORM MELANGE JEANS	8	FEBRIK	-
69	1	ESTANTE	313.8B.M.D	PUERTA METAL 35 METAL DOOR 35	GRIS GREY	-	-	-	-
70	1	ESTANTE	313.86.HDK	MODULO 70X37X96 MODULE 70X37X96	043 MANGO	-	-	-	-
70	1	ESTANTE	313.8A.HD	TRASERA TEXTIL FONOABSORVENTE 70X37 PHONO-ABSORBENT QUILTED BACK PANEL 70X37	-	UNIFORM MELANGE JEANS	8	FEBRIK	-
70	2	ESTANTE	313.8A.DD	COSTADO TEXTIL FONOABSORVENTE 37X37 PHONO-ABSORBENT QUILTED SIDE PANEL 37X37	-	UNIFORM MELANGE JEANS	8	FEBRIK	-
71	1	DEEP	312.11.K	SILLON 97 ARMCHAIR 97	CARBON	NABUK 11	12	NABUCK	-
72	1	ESTANTE	313.86.QDP	MODULO 140X37X134 MODULE 140X37X134	002 NATURAL	-	-	-	-
72	6	ESTANTE	313.8A.HD	TRASERA TEXTIL FONOABSORVENTE 70X37 PHONO-ABSORBENT QUILTED BACK PANEL 70X37	-	UNIFORM MELANGE SOLAR	8	FEBRIK	-
72	6	ESTANTE	313.8A.DD	COSTADO TEXTIL FONOABSORVENTE 37X37 PHONO-ABSORBENT QUILTED SIDE PANEL 37X37	-	UNIFORM MELANGE SOLAR	8	FEBRIK	-
73	1	ESTANTE	313.86.QDP	MODULO 140X37X134 MODULE 140X37X134	002 NATURAL	-	-	-	-
73	6	ESTANTE	313.8A.HD	TRASERA TEXTIL FONOABSORVENTE 70X37 PHONO-ABSORBENT QUILTED BACK PANEL 70X37	-	UNIFORM MELANGE SOLAR	8	FEBRIK	-
73	6	ESTANTE	313.8A.DD	COSTADO TEXTIL FONOABSORVENTE 37X37 PHONO-ABSORBENT QUILTED SIDE PANEL 37X37	-	UNIFORM MELANGE SOLAR	8	FEBRIK	-
73	3	ESTANTE	313.8B.T.H	PUERTA TEXTIL FONOABSORVENTE 70 PHONO-ABSORBENT QUILTED DOOR 70	-	UNIFORM MELANGE SOLAR	8	FEBRIK	-
74	1	ESTANTE	313.86.QDP	MODULO 140X37X134 MODULE 140X37X134	002 NATURAL	-	-	-	-
74	6	ESTANTE	313.8A.HD	TRASERA TEXTIL FONOABSORVENTE 70X37 PHONO-ABSORBENT QUILTED BACK PANEL 70X37	-	UNIFORM MELANGE SOLAR	8	FEBRIK	-
74	6	ESTANTE	313.8A.DD	COSTADO TEXTIL FONOABSORVENTE 37X37 PHONO-ABSORBENT QUILTED SIDE PANEL 37X37	-	UNIFORM MELANGE SOLAR	8	FEBRIK	-
74	1	ESTANTE	313.8B.T.D	PUERTA TEXTIL FONOABSORVENTE 35 PHONO-ABSORBENT QUILTED DOOR 35	-	UNIFORM MELANGE SOLAR	8	FEBRIK	-
74	1	ESTANTE	313.8B.M.H	PUERTA METAL 70 METAL DOOR 70	GRIS GREY	-	-	-	-
75	1	TORTUGA	305.15	PUF 65X50X42 POUF 65X50X42	041 MALAQUITA MALACHITE	GALAXY 948	7	KVADRAT	-
76	1	TORTUGA	305.65.B	BASE SILLON ARMCHAIR BASE	041 MALAQUITA MALACHITE	NABUK 27	12	NABUCK	-
76	1	TORTUGA	305.65.C	CABEZAL SILLON ARMCHAIR HEADBOARD	-	NABUK 27	12	NABUCK	-
77	1	TORTUGA	305.56	BASE BUTACA MINI MINI LOUNGE CHAIR BASE	006 ANTRACITA ANTHRACITE	GALAXY 948	7	KVADRAT	-
77	1	TORTUGA	305.56.R	RESPALDO BUTACA MINI MINI LOUNGE CHAIR BACK	-	GALAXY 948	7	KVADRAT	-

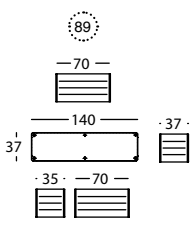
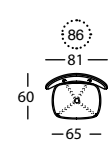
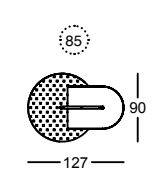
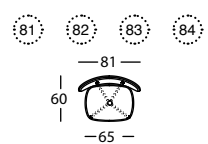
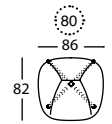
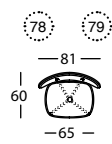

ID	UNI.	MOD.	REF.	DESCRIPCIÓN / DESCRIPTION	ACABADO FINISHES	TELAS / FABRICS		SERIES	MUESTRARIO SAMPLE
						ALMOHADA CUSHION	BASE		
78	1	TORTUGA	305.56	BASE BUTACA MINI MINI LOUNGE CHAIR BASE	043 MANGO	SPRINKLES PARROT		9	FEBRIK
78	1	TORTUGA	305.56.R	RESPALDO BUTACA MINI MINI LOUNGE CHAIR BACK	-	SPRINKLES PARROT		9	FEBRIK
79	1	TORTUGA	305.56	BASE BUTACA MINI MINI LOUNGE CHAIR BASE	053 TEJA BRICK RED	2802		3	118
79	1	TORTUGA	305.56.R	RESPALDO BUTACA MINI MINI LOUNGE CHAIR BACK	-	2802		3	118
80	1	TORTUGA	305.51	BUTACA SMALL ARMCHAIR	003 NOGAL WALNUT	8069		7	116
81	1	TORTUGA	305.56	BASE BUTACA MINI MINI LOUNGE CHAIR BASE	052 KLEIN	CRYSTAL FIELD 753		10	KVADRAT
81	1	TORTUGA	305.56.R	RESPALDO BUTACA MINI MINI LOUNGE CHAIR BACK	-	CRYSTAL FIELD 753		10	KVADRAT
82	1	TORTUGA	305.56	BASE BUTACA MINI MINI LOUNGE CHAIR BASE	052 KLEIN	BORREGUILLO HAIRY WOOL		3	-
82	1	TORTUGA	305.56.R	RESPALDO BUTACA MINI MINI LOUNGE CHAIR BACK	-	BORREGUILLO HAIRY WOOL		3	-
83	1	TORTUGA	305.56	BASE BUTACA MINI MINI LOUNGE CHAIR BASE	043 MANGO	ATLANTIC 64093		2	
83	1	TORTUGA	305.56.R	RESPALDO BUTACA MINI MINI LOUNGE CHAIR BACK	-	ATLANTIC 64093		2	
84	1	TORTUGA	305.56	BASE BUTACA MINI MINI LOUNGE CHAIR BASE	042 AMARILLO YELLOW	SPRINKLES BLUEBIRD		9	FEBRIK
84	1	TORTUGA	305.56.R	RESPALDO BUTACA MINI MINI LOUNGE CHAIR BACK	-	SPRINKLES BLUEBIRD		9	FEBRIK
85	1	BEETLE	315.F.420C	CONFIG. 420C					
			315.3A.4P	PANEL 4 PLANO PANEL 4 FLAT	-	STITCH PASSION		10	FEBRIK
			315.3A.2C	PANEL 2 CONCAVO PANEL 2 CONCAVE	-	ATLANCTIC 66041		2	112 / ATLANTIC
			315.3H.C	SOPORTE C SUPPORT C	042 AMARILLO YELLOW			-	-
86	1	TORTUGA	305.56	BASE BUTACA MINI MINI LOUNGE CHAIR BASE	052 KLEIN	ATLANTIC 62049		2	112 / ATLANTIC
86	1	TORTUGA	305.56.R	RESPALDO BUTACA MINI MINI LOUNGE CHAIR BACK	-	ATLANTIC 62049		2	112 / ATLANTIC
87	1	PION	284.71.FE	MESITA D50X40 OCCASIONAL TABLE D50X40	002 NATU- RAL / 126 QUARZO QUARTZITE			-	-
88	1	PION	284.48	BANQUETA D32X43 STOOL D32X43	127 TABACO TOBACCO			-	-
89	1	ESTANTE	313.86.QDK	MODULO 140X37X96 MODULE 140X37X96	002 NATURAL			-	-
89	4	ESTANTE	313.8A.HD	TRASERA TEXTIL FONOABSORVENTE 70X37 PHONO-ABSORBENT QUILTED BACK PANEL 70X37	-	UNIFORM MELANGE SOLAR		8	FEBRIK
89	4	ESTANTE	313.8A.DD	COSTADO TEXTIL FONOABSORVENTE 37X37 PHONO-ABSORBENT QUILTED SIDE PANEL 37X37	-	UNIFORM MELANGE SOLAR		8	FEBRIK
89	1	ESTANTE	313.8B.T.D	PUERTA TEXTIL FONOABSORVENTE 35 PHONO-ABSORBENT QUILTED DOOR 35	-	UNIFORM MELANGE SOLAR		8	FEBRIK
89	1	ESTANTE	313.8B.T.H	PUERTA TEXTIL FONOABSORVENTE 70 PHONO-ABSORBENT QUILTED DOOR 70	-	UNIFORM MELANGE SOLAR		8	FEBRIK

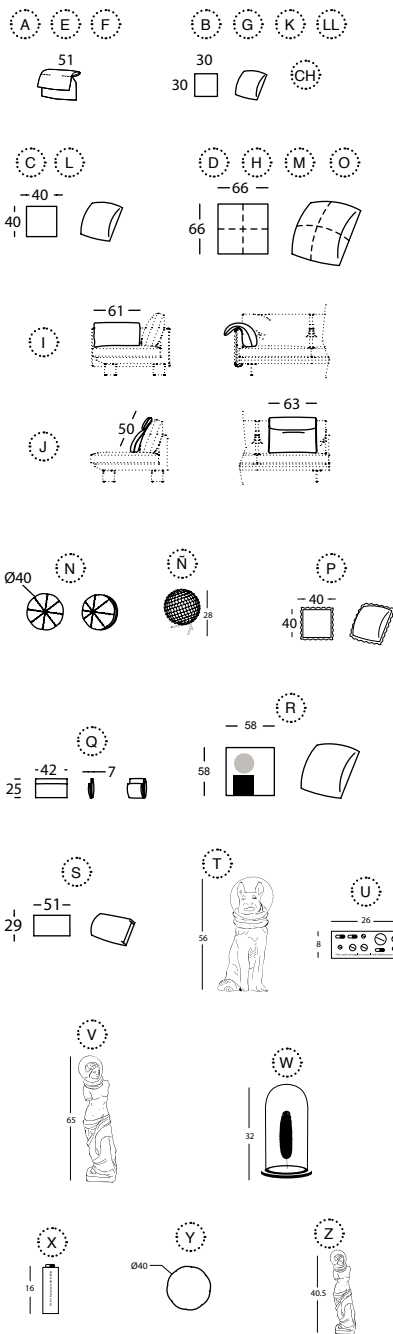

ID	MOD.	REF.	DESCRIPCIÓN / DESCRIPTION	ACABADO FINISHES	TELAS / FABRICS		SERIES	MUESTRARIO SAMPLE
					ALMOHADA CUSHION	BASE		
A	ESTOLA	316.25.F	ESTOLA COJIN CABECERILLA 51 ESTOLA HEADREST 51	-	POINT 008	-	-	KVADRAT PAUL SMITH
B	COJIN DECO	100.22.CC	COJIN DECORACION 30X30 CUSHION 30X30	-	FACET 73	4	107 / FACET	
C	COJIN DECO	100.22.DD	COJIN DECORACION 40X40 CUSHION 40X40	-	GALAXY 408	7	KVADRAT	
CH	COJIN DECO	100.22.CC	COJIN DECORACION 30X30 ESTOLA HEADREST 51	-	DROP LOLLIPOP	9	FEBRIK	
D	COJIN DECO	100.22.GG	COJIN DECORACION 66X66 CUSHION 66X66	-	6157	6	117	
E	ESTOLA	316.25.F	ESTOLA COJIN CABECERILLA 51 ESTOLA HEADREST 51	-	POINT 001	-	-	KVADRAT PAUL SMITH
F	ESTOLA	316.25.F	ESTOLA COJIN CABECERILLA 51 ESTOLA HEADREST 51	-	POINT 010	-	-	KVADRAT PAUL SMITH
G	COJIN DECO	100.22.CC	COJIN DECORACION 30X30 CUSHION 30X30	-	VANDELVIRA 56	-	-	
H	COJIN DECO	100.22.GG	COJIN DECORACION 66X66 CUSHION 66X66	-	VANDELVIRA 76	-	-	
I	DEEP	312.20	DEEP ALMOHADA BRAZO DEEP ARM CUSHION	-	6153	6	117	
J	DEEP	312.27	DEEP ALMOHADA LUMBAR DEEP LUMBAR CUSHION	-	8068	7	116	
K	COJIN DECO	100.22.CC	COJIN DECORACION 30X30 CUSHION 30X30	-	8068	7	116	
L	COJIN DECO	100.22.DD	COJIN DECORACION 40X40 CUSHION 40X40	-	RAZZLE DAZZLE GINGER	9	FEBRIK	
LL	COJIN DECO	100.22.CC	COJIN DECORACION 30X30 CUSHION 30X30	-	STEP 2440 65018	3	108 (1/2) / STEP	
M	COJIN DECO	100.22.GG	COJIN DECORACION 66X66 CUSHION 66X66	-	ATLANTIC 61166	2	112 / ATLANTIC	
N	MANDARINA	267.24.E.O	MANDARINA COJIN D40X14 FRUNCIDO MANDARINA WINKLED CUSHION D40X14	-	INFINITY 66108	3	113 / INFINITY	
N	THROUGH THE LOOKING GLASS	TTLG.3	DISCOWORLD X5	-	-	-	-	
O	COJIN DECO	100.22.GG	COJIN DECORACION 66X66 CUSHION 66X66	-	RAZZLE DAZZLE NATURAL	9	FEBRIK	
P	BANG!	299.22.EE.1	BANG! COJIN 40X40 YEMA-KLEIN BANG! CUSHION 40X40 YOLK-KLEIN	YEMA-KLEIN	-	-	-	
Q	TALO	290.23	TALO COJIN TALO CUSHION	-	STEP 2440 65018	3	108 (1/2) / STEP	
R	C1-C4	310.22.C4P	COJIN C1-C4 58X58X C4 PIEL C1-C4 CUSHION 58X58 - C4 LEATHER	-	-	-	-	
S	COJIN DECO	100.23.EC	ALMOHADA 51X29 PUNTAS COSIDAS CUSHION 51X29 STITCHED CORNERS	-	ARGO	ARGO	KVADRAT	
T	SPACE CLASSICS	SC.4	BOBBIE THE WONDER DOG	-	-	-	-	
U	MAGIC PILLS	MP.1	MAIN COURSE	-	-	-	-	
V	SPACE CLASSICS	SC.1	VENUS DE MILO XL	-	-	-	-	
W	RELICS FROM A PAST FUTURE	RFAPF.2	CUCUMBER SUCKED BY YOKO ONO	-	-	-	-	
X	MAGIC PILLS	MP.2	DESSERT	-	-	-	-	
Y	BANG!	299.22.E.2	BANG! COJIN D40 BLANCO-MUSGO BANG! CUSHION D40 SNOW-GRASS	BLANCO MUSGO	-	-	-	
Z	SPACE CLASSICS	SC.2	VENUS DE MILO X5	-	-	-	-	

SANCAL REF. 17009_ENIGMA

SANCAL DISEÑO, S.L.
 Pol. Ind. La Herrada C/ Príncipe de Asturias,
 18 30510 Yecla (Murcia) Spain
 Tel Esp. +34 968 75 15 03
 Tel. Eng. +34 968 71 90 62
 Tel. Fra. +34 968 71 90 61
 Fax +34 968 79 40 62
 e-mail web@sancal.com
 www.sancal.com

Art direction & styling Juan Ibáñez & Elena Castaño-López
 Photography Marcelo Martínez
 Coordination Esther Castaño-López
 Graphic project Juan Ibáñez & Juanma Domínguez

Copyright © Sancal Diseño S.L. 2017



